

Storage- and Mounting Instructions for endless woven conveyor belts of cotton and mixed threads

Important!

After receipt and inspection of our consignment the belts should always be stored in a dry area – unless they are installed immediately.

Pre-condition:

- Pre-condition for a straight run of conveyor belts is a perfectly mounted and adjusted machine. It is necessary to pay attention to the parallelism of drive, turn-around and tensioning elements. It is important, as well, that the equipment has been cleaned before the installation of the belt.
- The fabric belt must be mounted equally, in order to avoid a distortion of the fabric during the break-in period. It is the same thing with creases having occurred during the mounting procedure. This, too, can result in distorting fabric which will negatively affect the belt-run.
- Despite impregnation on the running side, which has to keep the fabric stable in size, a shrinking of up to 1.5% can occur in case of temperature impact of more than 45°C. Please, take that into consideration in case of installation of heat sources.
- In order to increase the belt life, it should be paid attention to an evenly spread pressure right hand/left hand of the moulding rollers towards the counter roller! Additionally, the moulding roller should be adjusted parallel towards the belt.

Break-in period:

1. Switch the belt control gear off or set it at “O” respectively.
2. Fit the belt and switch the machine on.
3. Watch the belt-run and, in case of unbalanced run, correct it with the help of the knife edge or a turn-around roller until it runs at least 2 minutes without adjusting centrally in the system.
4. Now switch the belt control gear on.

Note: The belt control gear now takes the task over to keep the belt in the middle of the conveying system. The belt control gear must never work one-sided because this leads to belt distortion.

Sources of error with belt shrinking:

- a. This is the ideal case.

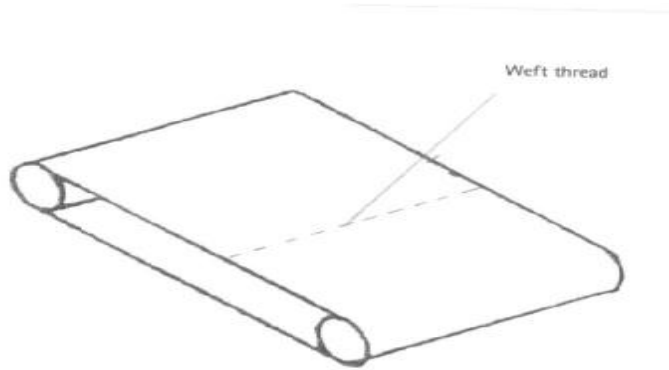

All adjustments which influence the belt are correct and the belt runs perfectly.

- b. The weft yarn moves out of place because the tracking roller works one-sided.

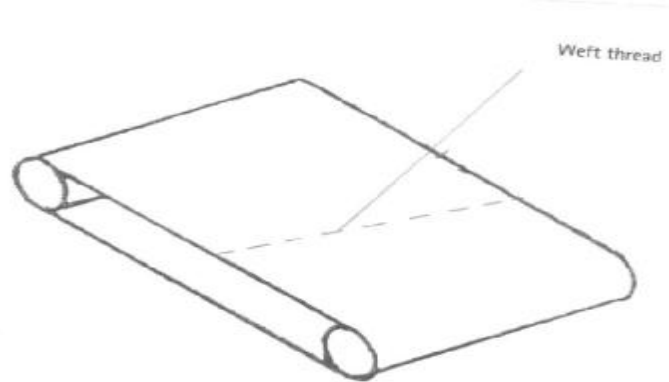

Stop the belt immediately in order to avoid a further distortion of the fabric! Open a new break-in period.

- c. The weft thread has got an arched shape.

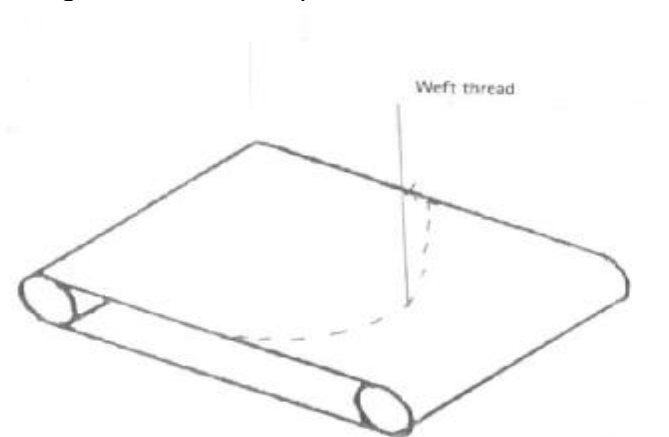

Please, check whether the reversing rollers bend due to great power. The tension of the belt is too strong. Dough residues on the drive and reversing rollers are to be removed. Check the knife edge and the scraper for wear. If there is, these parts are to be replaced with the next belt change.

Cleaning:

Normally, the belts are cleaned during the machine sand still. The belt must not be relaxed. It has to stay tensed because the belt shrinks in the length due to influence of humidity.